

# Instructions



## Repacking and Shipping a Phaser® 740 Color Printer in Original Packaging

First printing June 1998  
Z740-8  
Copyright © Tektronix, Inc.



# *Repacking Your Printer*

## **Before you start**

These instructions show you how to repack the printer in its original packaging. Proper repacking is necessary to protect the printer from damage during shipping or moving. Complete repacking is required before shipping. However, you can prepare the printer for a short move — such as between buildings or in a car to another site, for example — by just removing the toner cartridges.

If you do not have the original packaging material, you can order a Repacking Kit (part number 065-0576-00) by calling Tektronix Customer Support at 1-800-835-6100; outside the U.S., contact your local Tektronix office. Field office locations are listed at [www.tek.com/Color\\_Printers/contacts](http://www.tek.com/Color_Printers/contacts) on the Tektronix web site.

### **NOTE**

To keep the printer's warranty valid during shipping, you must first remove the transfer roller/waste bin, prepare the imaging unit, and move or ship the printer in its Tektronix shipping box with the appropriate packing materials. If you are returning the printer for service, call Tektronix for a return authorization number (RMA#).

## What you need

To repack the printer, you need the following:

- Original packing material
- Printer and accessories
- Lower Tray Assembly (if applicable)
- Two people to lift the printer. Without the components, it weighs about 47 kg (104 lbs.) and the Lower Tray Assembly weighs about 14 kg (31 lbs.).
- Between 30 to 60 minutes, depending on repacking experience.
- Toner vacuum (recommended). A toner vacuum is the most effective tool for cleaning spilled toner. However, only use a vacuum that is especially designed for laser printer toner. Standard household or shop vacuums will not work with toner dust. Following are part numbers for toner vacuums and accessories available from Tektronix:

### Toner Vacuums

Part number	Item
003-1496-00	115-Volt vacuum
003-1497-00	220/240-Volt vacuum
003-1498-00	Toner filter for the vacuums

## At a glance

Repacking consists of the following basic tasks:

- Removing and repacking media tray(s).
- Preparing and securing the imaging unit.
- Removing and repacking toner cartridges into the toner packing boxes.
- Cleaning the transfer roller/waste bin area.
- Detaching the Lower Tray Assembly (if applicable).
- Packing and securing the printer and its accessories.

## Repacking the printer

### Power off

1. Turn off the printer.
2. Remove the power cord and all cables.

### Prepare the media tray(s)

1. Remove the media tray from the printer, and remove the media from the tray. If you have the Duplex Unit and Lower Tray Assembly installed, remove the Duplex Unit. Repack it according to instructions on page 7.
2. Press down on the media tray's metal plate until it clicks and locks.
3. Insert the cardboard lock through the rear slot in the media tray, and turn it 180° clockwise to lock it in position.

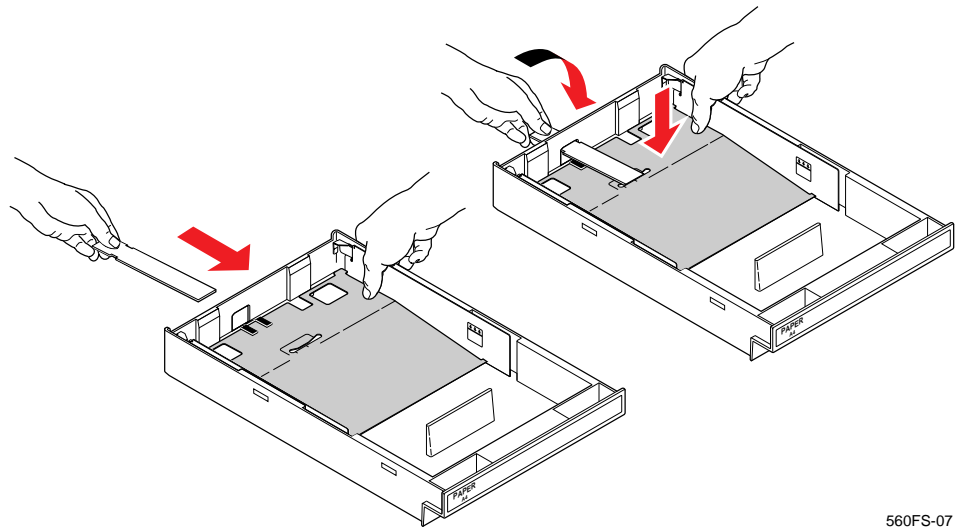

560FS-07

4. Re-insert the tray into the printer.
5. If you have additional media trays, put a cardboard lock into each of them, then repack the media trays for shipping or storage in their packing boxes.

### Prepare the imaging unit

1. Open the printer's front door.
2. Make sure that the two small knobs are tightened. If they are not, turn them **clockwise** to tighten.

3. Turn the upper lever 90° *counterclockwise*.

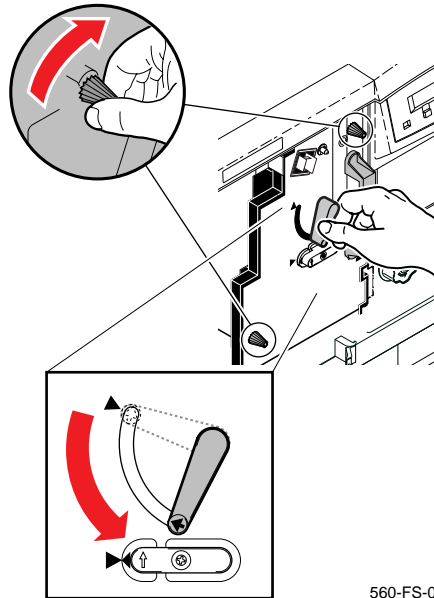

4. Close the printer's door.

### Remove the toner cartridges

#### CAUTION

Be careful not to leave the side door open for an extended time. Components can be damaged by light exposure.

1. Open the printer's right side door.

#### NOTE

Be careful not to touch the cartridge rollers, as toner may smear on your hands.

2. Remove the toner cartridges.
3. Pair cartridges together and repack them in the top cushion.

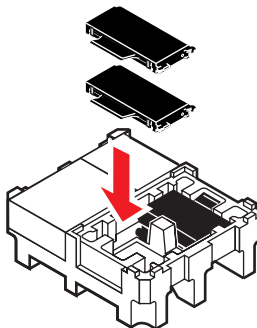

## Remove and discard the transfer roller/waste bin

### CAUTION

Remove the transfer roller/waste bin before shipping the printer. Failure to do so may damage the printer and invalidate the printer warranty.

1. Open the printer's left side door.
2. Pull out the paper feeder (shown in dotted outline).
3. Remove the transfer roller/waste bin.

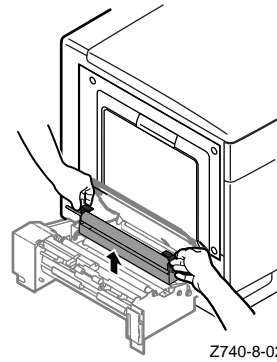

4. Rotate the blue handles down.
5. Using a piece of paper to keep your hands clean, push down on the transfer roller (A) to lock it onto the waste bin.

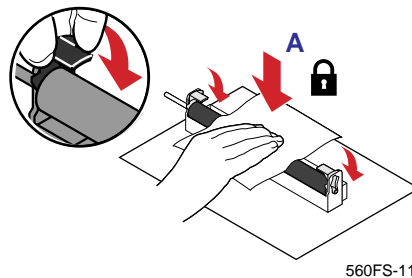

6. After locking, discard the transfer roller/waste bin.
7. Vacuum or wipe away any loose toner in the transfer roller/waste bin area of the printer.

### NOTE

A toner vacuum is the most effective tool for cleaning spilled toner. However, only use a vacuum that is especially designed for laser printer toner. Standard household or shop vacuums will not work with toner dust.

**Secure doors**

1. Close all doors and secure them with adhesive tape.

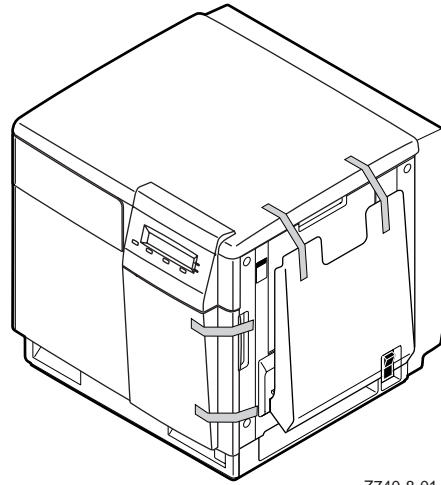
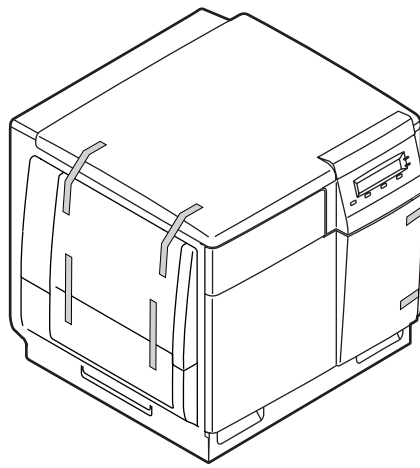

Z740-8-01



## Remove the Lower Tray Assembly (if applicable)

### WARNING

The printer weighs approximately 47 kg (104 lbs.) with the components removed; the Lower Tray Assembly weighs approximately 14 kg (31 lbs.). Observe standard safety precautions for lifting heavy objects.

1. If you haven't already done so, remove all media trays and the Duplex Unit, and repack them in their boxes.
2. Lift the printer up and away from the Lower Tray Assembly.

### WARNING

Never lift the printer and the Lower Tray Assembly together. You can damage the components and may incur personal injury. Always remove the printer before moving the Lower Tray Assembly.

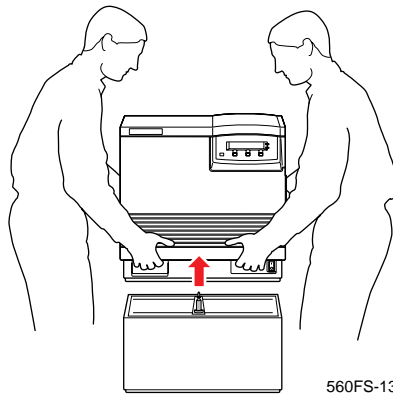

3. Repack the Lower Tray Assembly in its shipping box.

### Repack the printer and *all* accessories

1. Repack printer accessories in the original accessory packing boxes.
  - Include the power cord, cables, manuals, parallel cable adapter, and CD-ROMs.

#### NOTE

If the printer needs repair, refer to "Shipping the printer for repair."

2. Repack the printer and accessories boxes in the original shipping box.

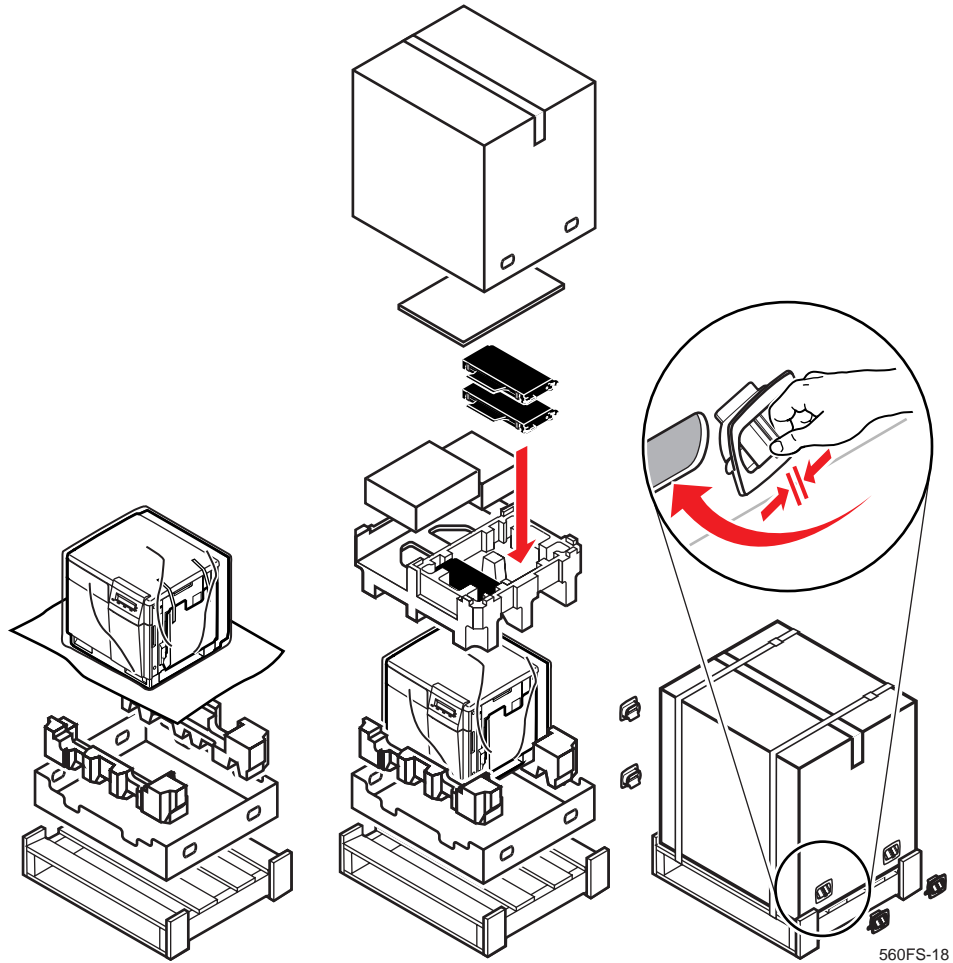

560FS-18

3. Using the banding supplies included with your printer, band the shipping box and wooden pallet.

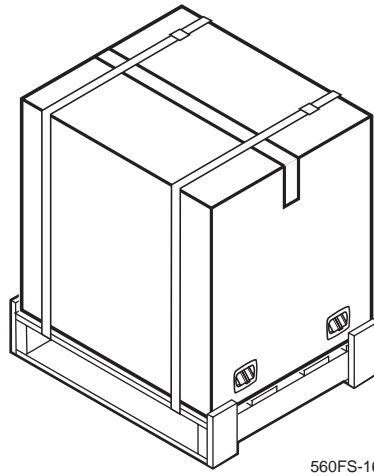

560FS-16

## Shipping the printer for repair

If you are shipping the printer to Tektronix for service, call 1-800-835-6100 for a return authorization number (RMA#). Outside the U.S., contact your local Tektronix office for service information.

- Write the RMA# on a sheet of paper. Attach this sheet to the top of the printer with adhesive tape.
- Write the RMA# on the outside of all cartons.
- Ship the printer and accessories to the following address:

**CPID-Depot Repair  
Tektronix M/S 83-172  
26600 SW Parkway  
Wilsonville, OR 97070-1000**